

WARNING: Read the manual carefully before the installation. The device must be installed and used in accordance with this manual. The device is designed to use for passenger vehicles with 12 Volts power network. The device must be connected to 12V and minus pole ground. Neither producer nor the seller are not responsible for any possible damages and losses which would result from im-proper installation, use or controll of the device, which would be different from the instructions listed below. By improper interference with the device or its modification you are at risk of damaging the device itself, or vehicle's power supply and void of warranty. For correct and error-free operation of your product, we recommend the installation to perform by professional service.

SYSTEM DESCRIPTION

PTS 410-VW is the rear parking assistant system with 4 ultrasonic sensors, designed for the VW/Škoda/Seat cars. The area behind the vehicle is electronically monitored while reversing. An obstacle is signalized acoustic way and the original display will show up the graphics of the parking assistant where shows which sensors detected an obstacle and how far you are from it. Closer you are to an obstacle, the beeping interval is shortened until the continuous tone (0.3 m). The system includes self test function of the sensors and dual intelligent learning function of untrue obstacles on the vehicle and therefore is ideal for vehicles with tow bar or spare wheel on the fifth door ..

Reach area and signalisation

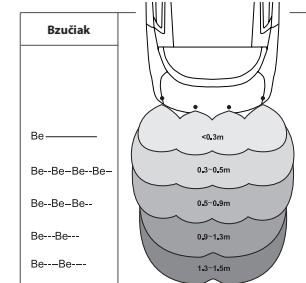

Sensors self test function

The system automatically check out the functionality of the connected sensors after the reverse gear is shifted. The buzzer beeps 1 time, if all sensors are OK. If some of the sensors are defective, the buzzer beeps 3 times.

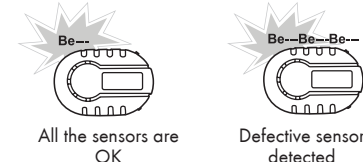

NOTE: If defective sensor detected, all other sensors would work properly in normal way.

Example of displaying parking assistant graphics on the radio unit RCD 310



Setting up the volume and the frequency of the buzzer

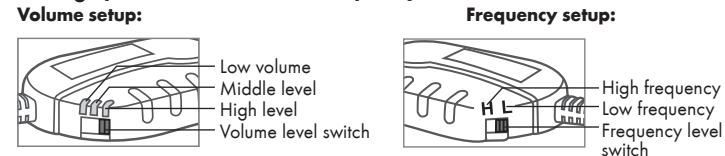

Sensors sensitivity level setup in relation to installation height level (switch no.1)

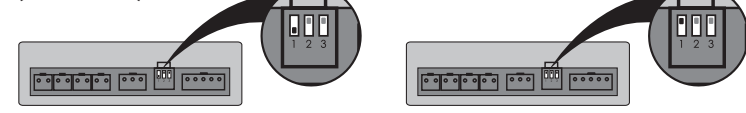

Switch no.1 in the „ON“ position
- standard sensitivity level
- recommended adjustment for sensors installed 50cm above the ground and higher

Switch no.1 in the „OFF“ position
- reduced sensitivity level
- recommended adjustment for sensors installed from 45 to 50cm above ground

Turning ON/OFF Anti-Hook function (Switch no.2)

If a vehicle is equipped with a tow bar or has spare wheel placed on the fifth door, it is appropriate to enable the Anti-Hook function. When the Anti-Hook function active, detected distance is increased about 20 cm between the sensor and the obstacle.

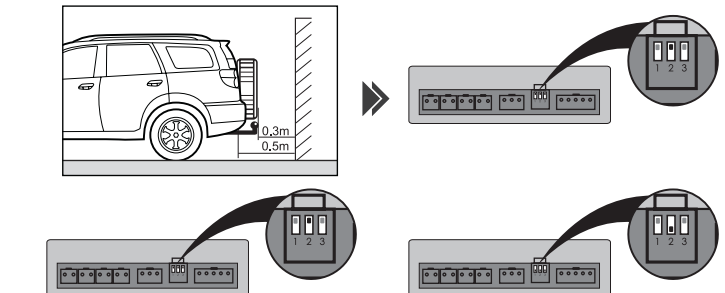

Switch no.2 in the „OFF“ position
Actual distance between the sensors and an obstacle signalled.

Switch no.2 in the „ON“ position
20 cm increased distance between the sensors and an obstacle signalled.

The learning function for the cars with tow bar or spare wheel on the fifth door.

Parking assistant may signal a false barriers mounted on the car like tow bar, spare wheel on the fifth door or various obstacles mounted near the sensors. Using the learning function, the system learns static obstacles around the sensor (tow bar, spare wheel, etc..) and will not signal it. To activate the learning function, follow these steps:

Activation of the learning function with reverse gear shifting

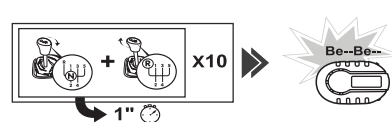

1. While the ignition is in ON position, shift the reverse gear from neutral 10x (gear shift change you need to get done within 1 second) the tenth time shifted reverse gear-let the gear in the reverse position.
 2. The buzzer will beep once after the two seconds.
 3. The buzzer will beep twice after another two seconds to confirm the end of programming mode.
- Note: While activated learning function, it is necessary to power the control unit of the parking assistant directly from reversing light bulbs. After the learning process is done, the parking assistant can be connected with CAN BUS module according the wiring diagram.

Deleting the learning function:

1. While the ignition is in ON position, shift the reverse gear from neutral 12x (gear shift change you need to get done within 1 second) the twelfth time shifted reverse gear-let the gear in the reverse position..
2. The buzzer will beep once after the two seconds.
3. The buzzer will beep long (2 secs) after another two seconds, for confirmation.

After the learning process is done, perform a functional test.

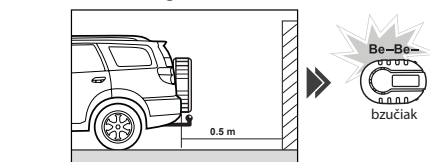

False detection may occur in the following cases:

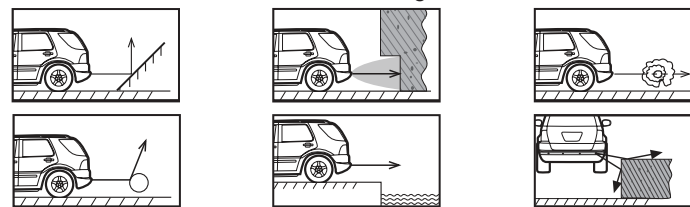

- test the system first, after the installation
- heavy rain, dirty or damaged sensor may cause a false alarms
- make sure that the self-test is completed and all the sensors are working properly, before you start reversing

Maintain of the sensors

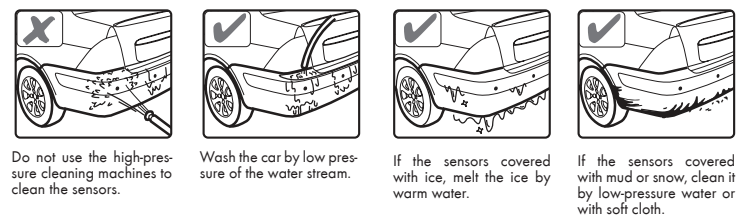

THE SYSTEM INSTALLATION

The system is designed for VW Group cars, the way it works with OEM car radio unit and the radio is able to show up the obstacles on its display. The sensors are installed in the rear bumper of 0.45m to 0.65m above the ground. The installation in the corners of the bumper is not recommended (damage in a collision). Before the installation, clean and prepare the parts of the bumper where the sensors will be placed. The control unit should be located in the interior of the vehicle, not to expose it to the effects of heat and humidity. Caution: Do not attach the control unit to the metal parts of the car!

Installation procedure:

- 1 Find a suitable location for the sensors
- 2 Measure and mark the spots for the sensors
- 3 Drill the holes for the sensors
- 5 Install the sensor in the holes and draw its wires to the control unit. Place the sensors in the arrow-up position
- 6 Mount the control unit with CAN bus module
- 7 Connect all connectors and power cables according to the wiring diagram
- 8 Using diagnostics enable the vehicle parking assistant (the display is able to show up the distance then)

Sensors location

Place the sensors so that no part of the vehicle obstructing the detecting.

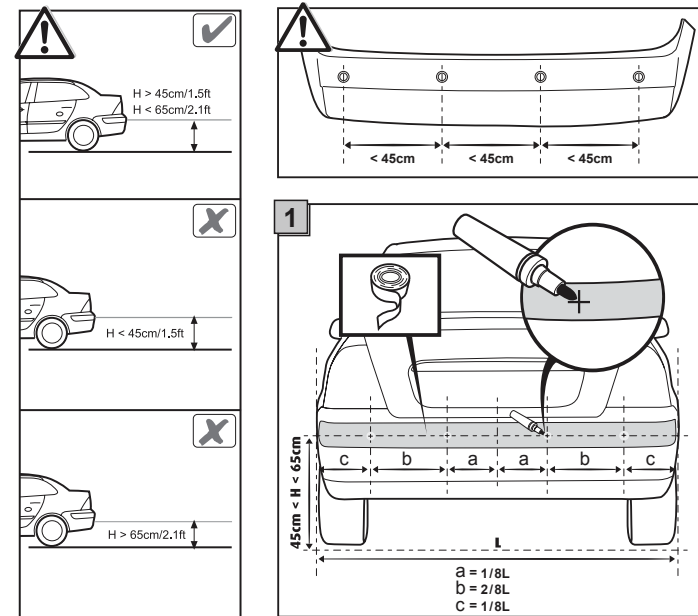

Replacing the sensors covers with different degrees of tilt

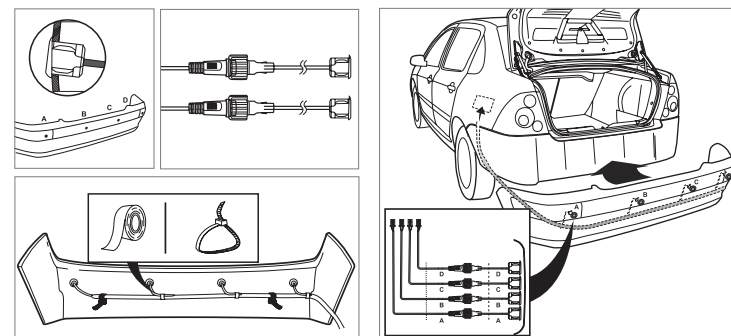
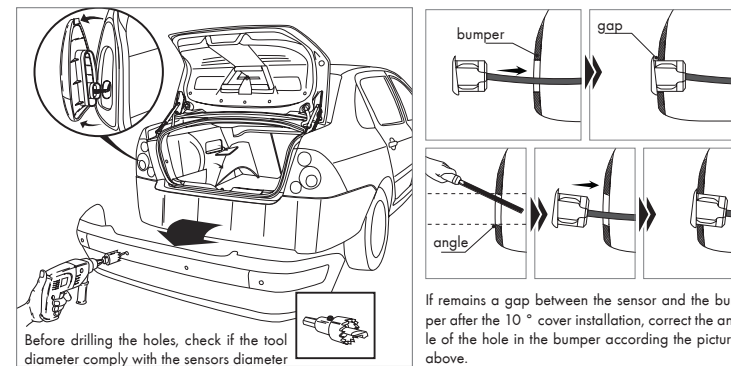
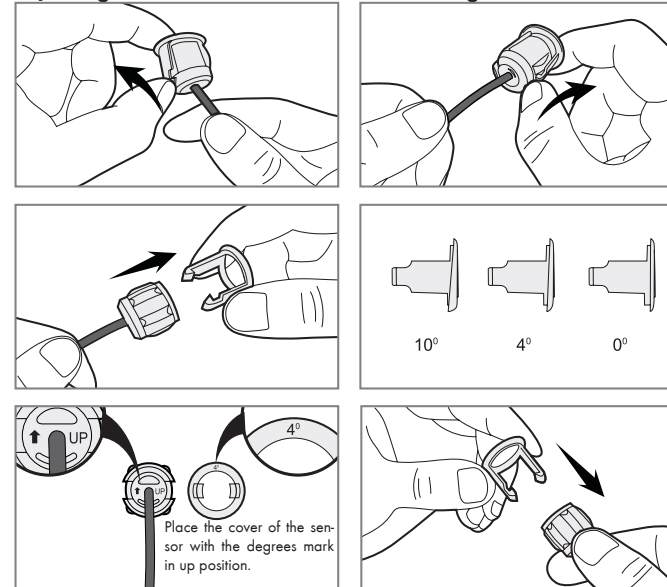

Control unit location

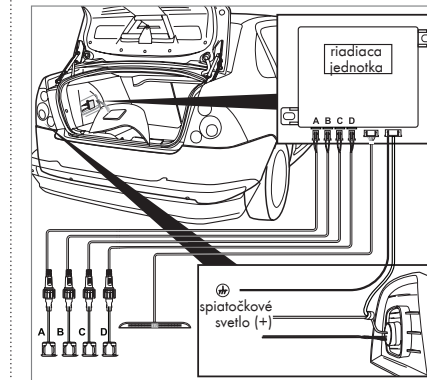

Buzzer location

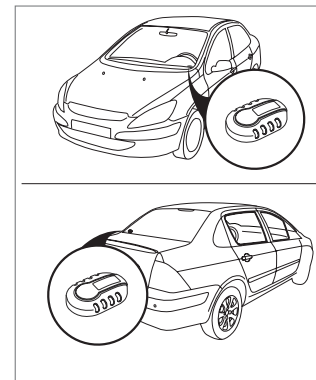

System functionality testing

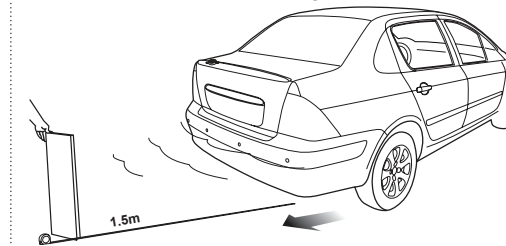

Check the functionality of the system using a wooden board. Switch on the ignition (do not start the car!) And shift the reverse gear. Stand behind the vehicle 1.5 meters behind and gradually zoom in to a vehicle with a board facing a sensor up to a distance of 0.3 m. Test each of the sensors this way.

WIRING DIAGRAM

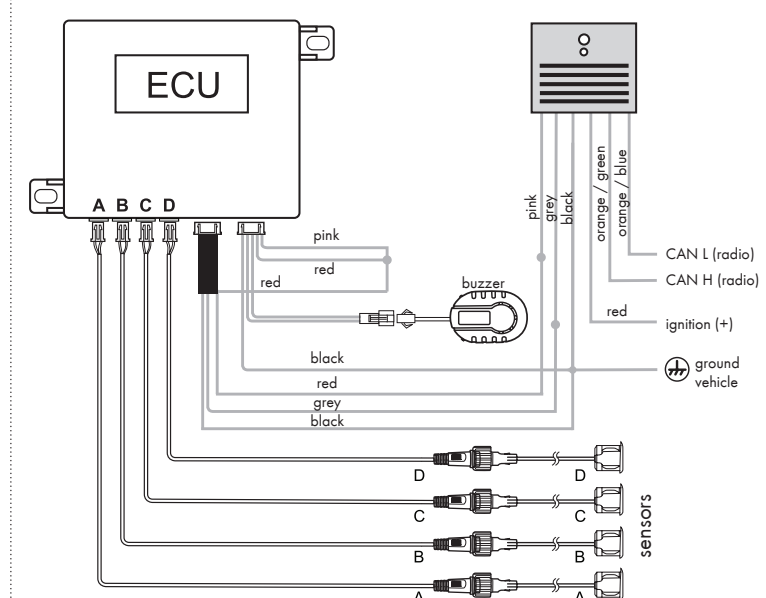

NOTE: CAN BUS module output wires orange/green and orange/blue connect to the wires of data bus CAN BUS leading to car radio unit.

Important Notice

- Parking assistant aids when reversing and parking. Driving skills, low speed, use of the mirrors, etc. is always important when reversing and parking.
- 1 parking sensor is designed for vehicles with 12V DC power supply.
 - 2 The system should be installed by trained technicians.
 - 3 Do not draw the harness close to heat sources and electrical components.
 - 4 We recommend to check carefully the places for the sensors before drilling the holes.
 - 5 After the installation is complete, check the functionality of the system.

Declaration

The system serves only as an additional system to ease the parking and therefore the dealer nor distributor are not responsible for damage caused during parking, where the system is installed.

TECHNICAL PARAMETERS	PTS 410
Supply voltage	9-16V
Working temperature	-40°C to +80°C
Current consumption	<250mA
Detection range	0,3 - 2,5m
Sound signalization range	0,3 - 1,5m